

# TRACEPAK<sup>®</sup> INSTRUCTIONS

## ***Contents***

	<b><i>Page</i></b>
Installing TRACEPAK Tubing Bundles	1-5
Connection Kits	6
Termination Kits	7
Heat Shrink Boot End Seals (TPKHS)	8
Enclosure Entry Seals (TPKES)	9
Silicone End Seal (TPKSK)	10
Jacket Patch Kit (TPKJP-1, TPKJP-2)	11
High Temperature Jacket Kit (TPKJP-3, TPKJP-4)	12
Line Sensing Thermostat	13
Controllers (HC5)	14

# TRACEPAK

Installation instructions are provided to give the field engineer and installers the necessary information to install TRACEPAK in an efficient and effective manner. These recommendations are suggestions and do not imply that only these methods can be used.

**Caution:** All installations must be done in accordance with applicable local codes. To satisfy code and approval agency requirements O'Brien Power Connection and End Termination Kits must be used. Approvals and product warranty may be void if alternate connection kits are used or installation instructions and proper end sealing are not followed.

## Receiving

- Ensure that the protective caps placed over the ends of the bundle are firmly in place.



## Storage

- All bundle ends must be sealed at all times. (See "Sealing the Ends.")
- Cover from weather.
- Protect from mechanical damage.
- Temperature Range
  - 60°F to 140°F (-50°C to 60°C)
  - 40°F to 140°F (-40°C to 60°C)

## Determining Required Length and Routing

- Seal all ends of the tubing bundle during installation. (See "Sealing the Ends.")
- Route along existing structures such as beams and columns to provide support.
- Avoid areas where the ambient temperature may exceed 110°F (45°C).
- Maintain 1/2" (12mm) space between bundles.
- Measure square into corners. (The length of

TRACEPAK required to make a 90 degree bend is about 13" (330mm). Measuring square into the corner will give you 16" (410mm). The extra 3" (80mm) is part of your safety factor to ensure you have enough length.)

- Allow 12" - 18" (300mm to 450mm) of straight tubing bundle before connecting to fittings.
- Add enough length to TPH and TPL bundles to connect the tracer to the supply connection and to the return system.
- Add enough length to TPE bundles to connect the power supply. Include the length from the process connection locations to the junction box and 6" (150mm) inside the junction box. Include the required length of tracer to heat valves or other equipment at the end of the bundle.
- **Caution: Electric Traced Systems** Consult the installation instructions for the tracer. You may be required to make connections and terminations at a particular point on the tracer. If so, you will need to locate these points before cutting the bundle to its final length. Failure to properly install the electric tracer can lead to excessive heating, tracer failure and damage to the tubing bundle.

## Supporting

- Supports and hangers must have a large surface area and be designed so they can not be overtightened to crush the tubing bundle. Do not use U-bolts as supports.
- Angle iron may be used as a support. Place the bundle in an angle sized 1/2" (12mm) larger than the largest dimension of the bundle and secure it with metal or plastic straps. Do not use wire ties.
- Cable tray may be used as a support. Maintain a minimum of 1/2" (12mm) space between bundles.
- Maximum Support Centers
  - Horizontal Runs - 6 feet (2 meters)
  - Vertical Runs - 15 feet (5 meters)



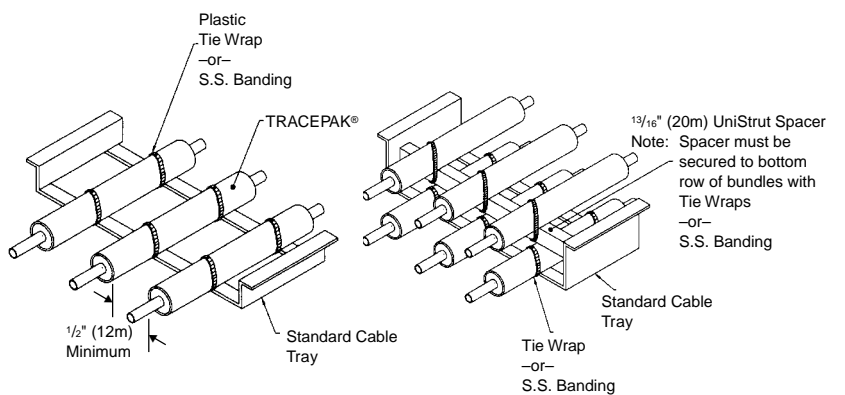
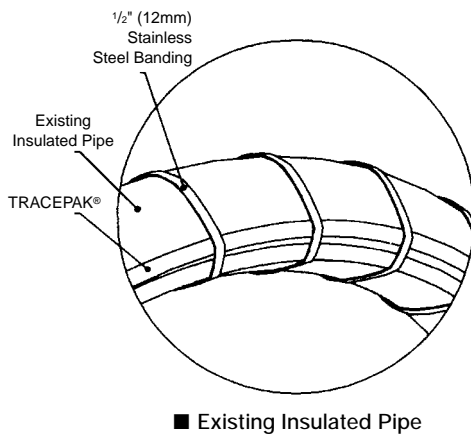
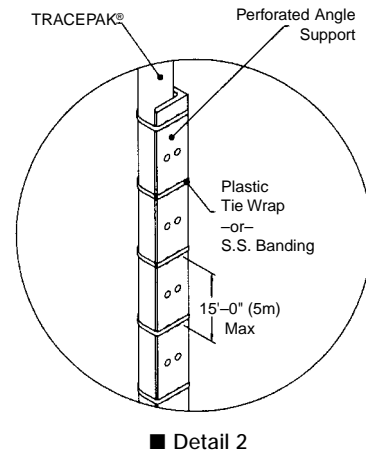
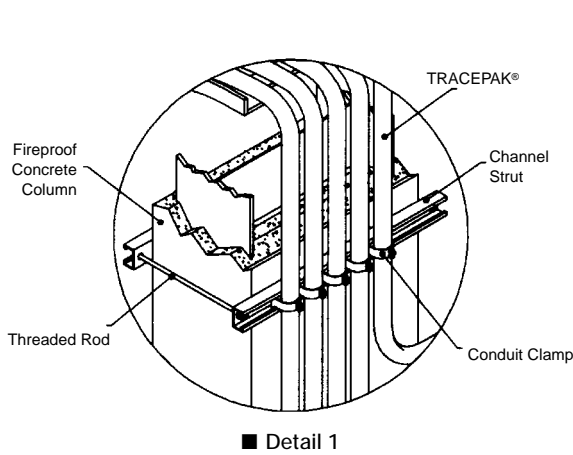
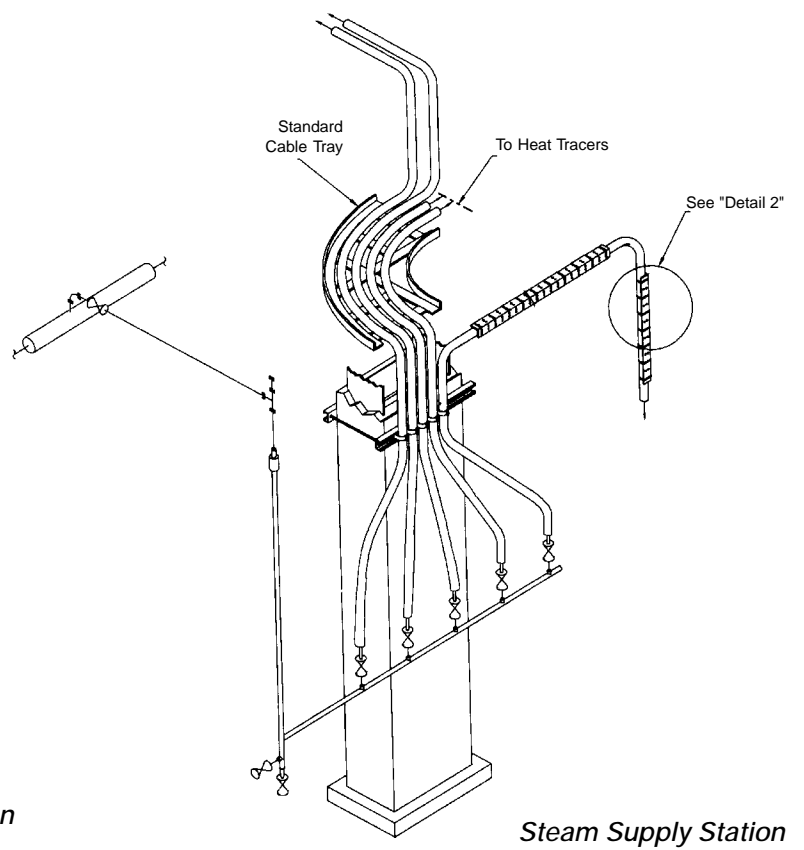
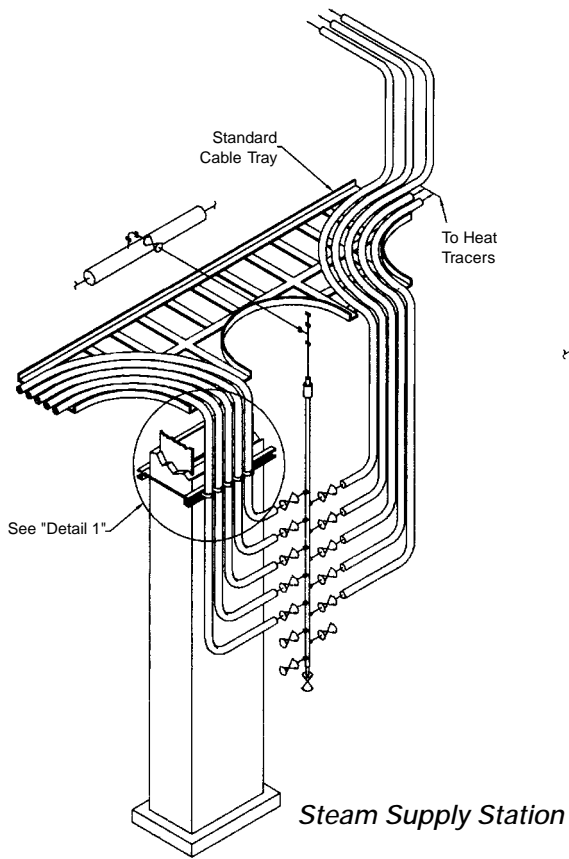

## ***Uncoiling and Straightening***

Method 1 - Roll it out on the floor or other flat surface.  
This will leave a slight bow that can be taken out by hand.



Method 2 - Use a second smaller spool to straighten the product as it is taken off of the larger shipping spool.



## ***Bending***

- The jacket will wrinkle when the bundle is bent. This is a normal condition and does not affect the performance or life of the bundle.
- Do not exceed the minimum bending radius of 8" (200mm).
- Use the O'Brien Bundle Bending Tool or a mandrel with the minimum bending radius such as a small spool.
- Bend on the small dimension. The bundle will tend to twist and then bend on this dimension naturally.



- To bend on the other (larger) dimension:  
Method 1 - Make two back to back bends on small dimension and twist the bundle in the direction you want it to go.



- Method 2 - Grasp the bundle firmly and twist it 90°. Then make the bend. This technique may also be used to position the tubing for process connection.



## Sealing the Ends

- All ends of the bundle must be sealed temporarily during installation. Use a plastic bag and tape it in place to seal the end of the bundle.
- TPKSK Silicone sealant – see page 10
- TPKHS Heat shrink boots – see page 8
- TPKJP Jacket patch – see page 11 & 12
- TPKEs Entry Seal – see page 9

## Process Connections with O'Brien Centerline Tool

- Allow enough bundle length to connect steam to supply/return or the electric tracer to the power

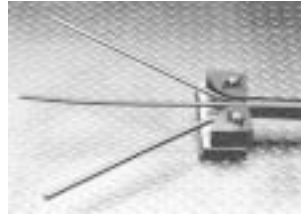

- supply junction box/termination kit.
- Make the required tubing bends with a tubing bender or the O'Brien 2<sup>1</sup>/<sub>8</sub>" (54mm) Centerline Tool before sealing the end of the bundle.
- Permanently seal the end of the bundle. Install boots before cutting tubes to length.

## Tracer Connections

- Electric tracers must be connected and terminated using approved power connection and termination kits. See page 6 & 7.
- When determining the length of the bundle, be sure to add enough length to bring the electric tracer into the junction box or the steam tracer to the supply and/or return connection. (See caution for electric tracer systems under Determining Required Length and Routing.)

## Temperature Control

- Many installations do not require secondary temperature control. When temperature control is required the following accessories are offered.
  - TPKTS-B-7 Line Sensing Thermostat, NEMA 7 Housing, 22 amp 125/250 VAC.
  - TPKTS-EX-02 Line Sensing Thermostat, CENELEC standards approved EEx d IIC T6, 22 amp 250VAC.
  - TPKTS-A-7 Ambient Sensing Thermostat, NEMA 7 Housing, 22 amp 125/250 VAC.
  - TPKTS-EX-04 Ambient Sensing Thermostat, CENELEC standards approved EEx d IIC T6, 22 amp 250 VAC.
  - HC5 Dial Set Point On/Off Controller for use with Thermocouple or RTD Sensors
- If a line sensing thermostat is used see page 13 for instructions on field installation of the temperature sensor.

## Labeling

- Labeling requirements for electric traced piping systems are determined by the prevailing code governing the installation. The installer is cautioned to comply with the unique labeling requirements of the governing code before completion of the installation.

## Model Number

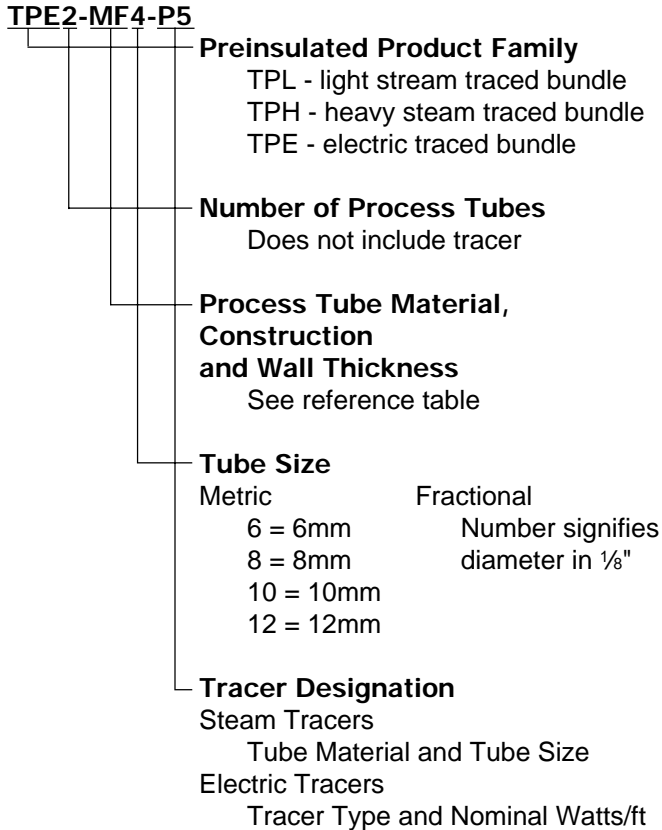

"Z" in a model number designates that something is special about the bundle. The "Z" is defined on the packing list, acknowledgment and invoice.

## S-LINE Preinsulated Tubing

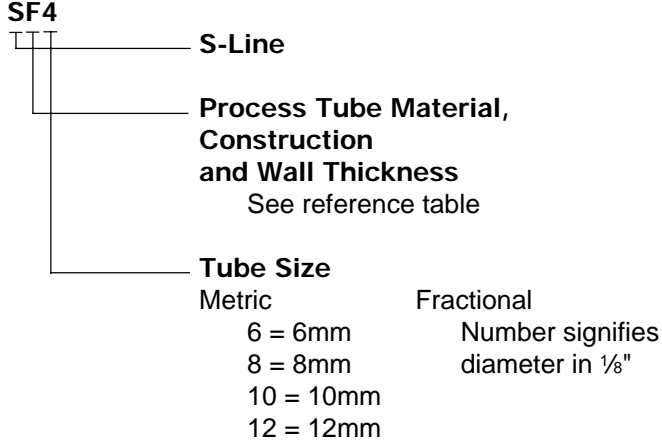

## Reference Tables

### Tubing

MF	1.0mm wall	316 SS seamless
MB	1.5mm wall	316 SS seamless
MD	1.0mm wall	copper
MG	1.0mm wall	PFA Teflon®
A	0.035 wall	316 SS welded
B	0.049 wall	316 SS seamless
C	0.032 wall	copper
D	0.035 wall	copper
E	0.049 wall	316 SS welded
F	0.035 wall	316 SS seamless
G	0.030 wall	PFA Teflon
H	0.062 wall	PFA Teflon
J	0.030 wall	copper
K	0.065 wall	316 SS seamless
M	0.049 wall	copper
N	0.035 wall	Monel 400
P	0.049 wall	Monel 400

### Electric Tracer

<b>B</b>	120V High Temperature
<b>J</b>	120V Freeze Protection
<b>MN</b>	240V High Temperature
<b>N</b>	240V High Temperature
<b>N15, 20</b>	240V High Temperature
<b>P</b>	240V Freeze Protection

## Suggested Installation Tools

- Bundle Bending Tool
- 2 1/8" (54mm) Centerline Tube Bender
- Installation Video



# CONNECTION KITS

## Select Correct Power Connection and End Termination Kits

TRACER	DESCRIPTION	POWER CONNECTION			END TERMINATION		
		FM/CSA		CENELEC	FM/CSA		CENELEC
		Div 1	Div 2	Zone 1			Zone 1
<b>B</b>	120V High Temperature	TPC1 (CSA)	T210-PC	—	TPCI (CSA)	T210-ET	—
<b>J</b>	120V Freeze Protection	TPC1 (CSA)	T210-PC	T9310-PC	TPCI (CSA)	T210-ET	T310-ET10
<b>MN</b>	240V High Temperature	TPC1 (CSA)	T210-PC	T9310-PC	TPCI (CSA)	T210-ET	T310-ET10
<b>N</b>	240V High Temperature	TPC1 (CSA)	T210-PC	T9310-PC	TPCI (CSA)	T210-ET	T310-ET10
<b>N15, 20</b>	240V High Temperature	TPC1 (CSA)	T210-PC	T9310-PC	TPCI (CSA)	T210-ET	T310-ET10
<b>P</b>	240V Freeze Protection	TPC1 (CSA)	T210-PC	T9310-PC	TPCI (CSA)	T210-ET	T310-ET10

Detailed installation instructions are included with each kit.



T210-PC

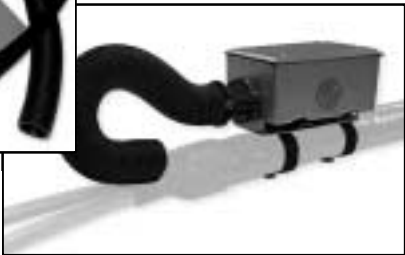

- FM Approved and CSA Certified Class I Div. 2 termination kit for use with any wattage B, N, J, or P tracer. Includes junction box and bundle mounting bracket with adjustable straps. Junction box also includes surface mounting feet.



T9310-PC



- Approved to CENELEC standards for hazardous area locations. Use with any wattage P, MN and N15 or N20 tracers. Installs in customer supplied junction box with M25 hub.



TPC1

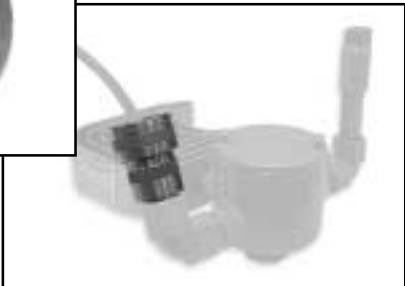

- CSA Certified Class I Div. 1 power connection or end termination kit for use with any wattage B, J, MN, N, or P tracer. Installs in customer supplied junction box with 1/2" npt hub.

# TERMINATION KITS



T210-ET

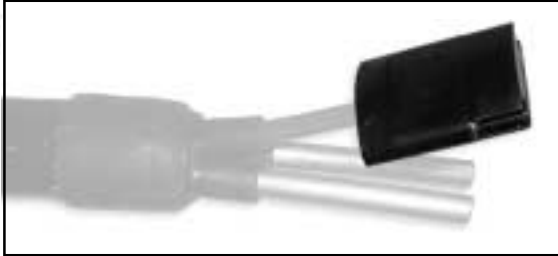

- FM Approved and CSA Certified Class I Div. 2 termination kit for use with any wattage B, N, J, or P tracer.



T310-ET10

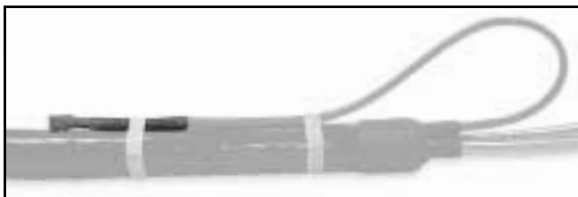

- Approved to CENELEC standards for hazardous area locations. Use with any wattage P tracer.



T310-ET13

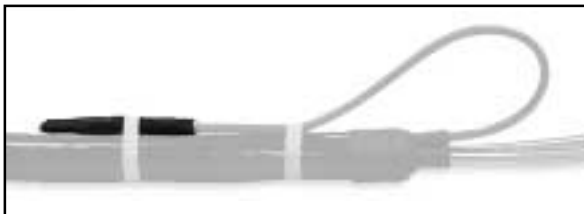

- Approved to CENELEC standards for hazardous area locations. Use with any wattage MN and N15 or N20 tracers.

## TPKHS - Heat shrink boots

TPKHS is a series of heat-shrinkable end seal boots made of a thermally stabilized, modified polyolefin. They are designed to provide a weatherproof seal at the end of tubing bundles. These boots may be used for process temperatures up to 400°F (204°C).

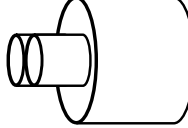
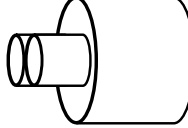
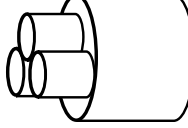
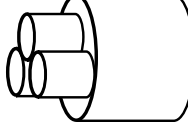
	Body dia. Min/Max	Leg dia. Min/Max
 <b>TPKHS-E1</b>	0.375"/1.30" (9mm/33mm)	—
 <b>TPKHS-C2</b>	0.95"/1.90" (24mm/48mm)	0.30"/0.75" (8mm/19mm)
 <b>TPKHS-D2</b>	0.45"/1.60" (11mm/40mm)	0.15"/0.55" (4mm/14mm)
 <b>TPKHS-A3</b>	1.40"/2.40" (36mm/60mm)	0.50"/1.13" (12mm/28mm)
 <b>TPKHS-B3</b>	0.90"/1.70" (22mm/43mm)	0.30"/0.80" (8mm/20mm)

## TPKHS Selection

Bundle Family	Process Tube	Tracer Tube Size	Model Number Size	Bundle Family	Process Tube	Tracer Tube Size	Model Number Size
<b>S-LINE</b>	1/4" (6mm)		*TPKHS-E1	<b>TPH1</b>	3/8" (8mm)	3/8" (8mm)	TPKHS-C2
	3/8" (8mm)		TPKHS-E1		1/2" (12mm)	1/2" (12mm)	TPKHS-C2
	1/2" (12mm)		TPKHS-E1		1/2" (12mm)	3/8" (8mm)	TPKHS-C2
<b>TPL1</b>	3/8" (8mm)	3/8" (8mm)	TPKHS-C2	<b>TPH2</b>		1/2" (12mm)	TPKHS-C2
		1/2" (12mm)	TPKHS-C2		3/8" (8mm)	3/8" (8mm)	TPKHS-B3
	1/2" (12mm)	3/8" (8mm)	TPKHS-C2		1/2" (12mm)	1/2" (12mm)	TPKHS-A3
<b>TPL2</b>		1/2" (12mm)	TPKHS-C2	<b>TPE1</b>	1/4" (6mm)		TPKHS-D2
	3/8" (8mm)	3/8" (8mm)	TPKHS-B3		3/8" (8mm)		TPKHS-C2
		1/2" (12mm)	*TPKHS-A3		1/2" (12mm)		TPKHS-C2
	1/2" (12mm)	3/8" (8mm)	*TPKHS-A3		1/4" (8mm)		*TPKHS-B3
	1/2" (12mm)	TPKHS-A3	<b>TPE2</b>	3/8" (8mm)		TPKHS-B3	
				1/2" (12mm)		TPKHS-B3	

\*Boot leg should be pinched with pliers while hot and held until cool to reduce leg diameter.

## Installation

- Cut back the bundle leaving the desired length of tubing exposed. This can be as short as 13" (160mm).
- Spread the tubes apart enough to fit into the legs on the end of the boot. We suggest that you bend the process tubes to the correct instrument connection centers before installing the boot. This will result in a more compact installation. Use a tube bender or the O'Brien 2 1/8" (54mm) centerline bending tool to make the required bends.



- Slip the boot over the end of the bundle with one tube or tracer in each leg until the bundle seats at the bottom of the boot. Be careful not to nick or cut the boot. Nicks and cuts will cause the boot to split during heat shrinking.
- Use a heat gun to shrink the boot over the bundle, tubes and tracer. Move the heat source back and forth over the boot applying heat evenly. Once the boot has assumed the shape of the bundle and the tubes, stop applying heat. Further heating will not make the boot shrink more tightly. If required, the boot leg should be pinched with pliers while hot and held till cool to reduce the leg diameter. Cut tubing and tracer to length required for instrument and tracer connections.

**\*CAUTION\***  
**When applying a heatshrink boot to a product with Teflon or plastic tubing, take care not to overheat the tubing.**

# TPKES

## TPKES - Entry Seal

TPKES The heat-shrinkable entry seal provides a waterproof fitting where TRACEPAK enters an enclosure. They can be added to parting line or surface mounted plates on VIPAK enclosures or any enclosure. The thermally stabilized, modified polyolefin entry seal consists of an O-ring assembly that seals at the enclosure and a heat-shrinkable nose that seals to the TRACEPAK bundle.

## TPKES Selection (Also ES)

Model Number	Max. Panel Thickness (A)	Maximum I.D. Nose (B)	Minimum I.D. Nose (C)	Mounting Hole Diameter (D)
TPKES-4	0.50" (12mm)	1.60" (40mm)	0.75" (19mm)	2.00" (50mm)
TPKES-4S	1.00" (25mm)	2.10" (51mm)	0.75" (19mm)	2.38" (60mm)
TPKES-5	1.00" (25mm)	2.75" (70mm)	1.43" (36mm)	3.50" (88mm)

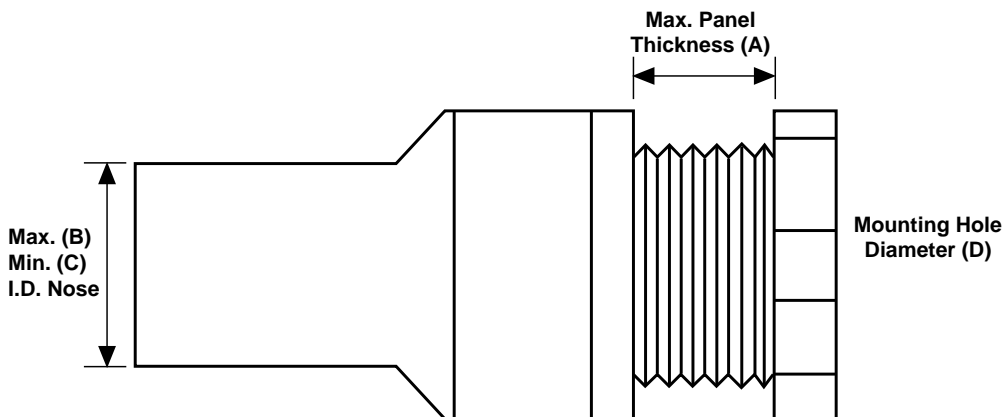

## Installation

- Place rigid, externally threaded nut through hole, so flanged end is on the inside of enclosure.
- If the enclosure is purged or kept at a positive pressure, place O-ring over threaded end and position against outside of enclosure. Otherwise the O-ring may be omitted to provide additional thread engagement.
- Screw shrinkable, internally threaded nose on to rigid nut and tighten using appropriate spanner wrenches.
- Insert TRACEPAK bundle through expanded opening and make necessary connections.
- Shrink expanded nose by applying heat with a heat gun. Move the heat gun back and forth over the nose applying heat evenly. Once the nose has assumed the shape of the TRACEPAK bundle, discontinue heat. Further heating will not make the nose shrink tighter.

O'Brien's RTV end sealant is a black adhesive/sealant which cures to a tough rubbery solid upon exposure to moisture in the air. The cure time is 24 hours at 77°F and (25°C) and a relative humidity of 50%. Its maximum service temperature extremes are -60°F to 450°F (-60°C to 210°C). It has excellent resistance to weather, oil, and many chemicals.

TPKSK-10 will seal approximately 10 bundle ends.

***Even though O'Brien's TRACEPAK products use a non-hygroscopic, non-wicking insulation, all bundle ends must be sealed to prevent contamination of the insulation.***

To install the end sealant, follow these instructions:

- Cut the bundle square on the end leaving the desired length of tubing exposed.
- Bend the process tubes to the correct instrument connection centers using a tube bender or the O'Brien 2<sup>1</sup>/<sub>8</sub>" (54mm) centerline tool.
- Cut the insulation back under the jacket about <sup>3</sup>/<sub>8</sub>" (10mm). **Caution:** It is important to cut the insulation out rather than pushing it back.
- Fill the end with end sealant making sure that all exposed insulation is protected.

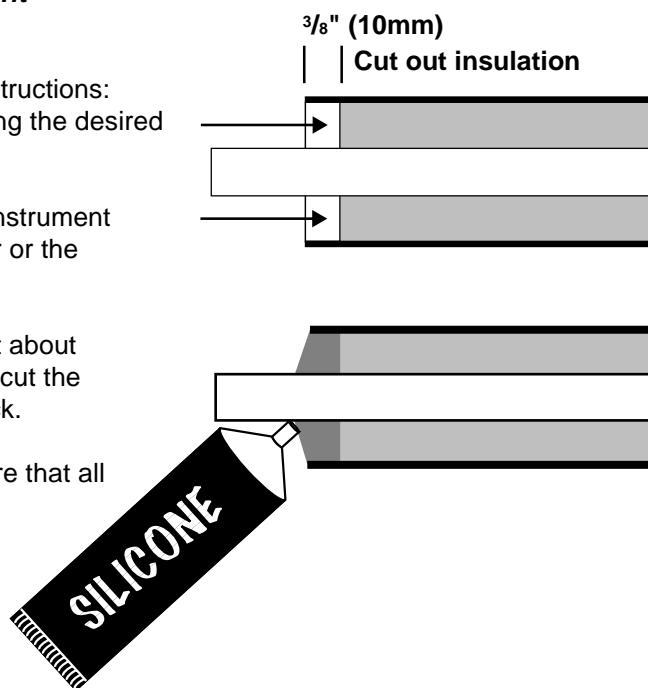

# TPKJP-1, TPKJP-2 JACKET PATCH

## For process tube temperatures up to 400°F (204°C)

O'Brien's Jacket Patch Kit is made up of thermal insulation, fiberglass tape to hold the insulation in place, and a black self-sealing rubber patch for weatherproofing the bundle. It is to be used to insulate an area where two bundles have been spliced together and the tubes connected with a tube fitting.

*\*If your tubing bundle has an innermost layer of woven glass insulation, use the High Temperature Jacket Patch Kit (TPKJP-3 or -4).*

### To install the jacket patch kit at a splice.

- Cut the ends of both bundles off square, exposing only the needed length of tubing\*.
- Splice the tubes together using a standard compression type fitting. Wrap the area with the insulation until the diameter is built up to equal the diameter of the jacket on the bundle. Use the fiberglass adhesive tape to hold the insulation in place.
- Cut the black rubber patch so that it extends over the existing jackets 1" (25mm). Remove the protective wax paper backing and wrap it around the patch area. Leave the clear protective layer in place and facing out. Overlap the ends by at least 1/2" (12mm) and press it into place. Use the fiberglass tape to hold it in place and prevent separation of the seams until it cures.

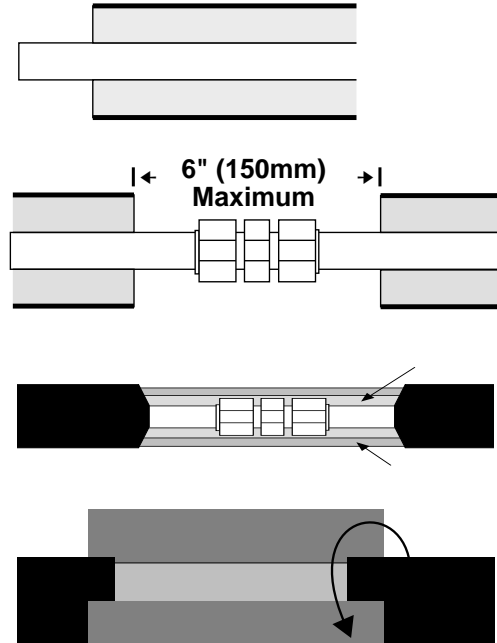

### To install the jacket patch kit at a bundle end.

- Cut the end of the bundle off square, exposing only the needed length of tubing\*.
- Wrap insulation around the tubes and fittings. At the end where the patch material will end, wrap insulation around the individual tubes to build the diameter to equal the bundle.
- Cut the patch material to extend over the bundle jacket 1" (25mm) and past the insulation on the individual tubes 3/8" (10mm).
- Remove the protective wax paper backing and wrap it around the patch area. Leave the clear protective layer in place and facing out. Overlap the ends by at least 1/2" (12mm) and press it into place. Use the fiberglass tape to hold it in place and prevent separation of the seams.
- Fill the end with RTV sealant, such as O'Brien TPKSK, making sure that all exposed insulation is protected.

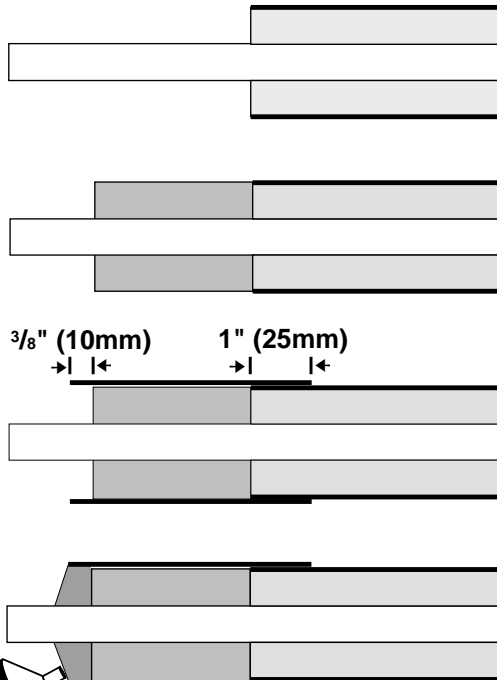

# TPKJP-3, TPKJP-4 HIGH TEMPERATURE JACKET PATCH

## For process tube temperatures over 400°F (204°C)

O'Brien's High Temperature Jacket Patch Kit is made up of woven fiberglass insulation, fiberglass strip insulation, fiberglass adhesive tape to hold the insulation in place, and a black self-sealing rubber patch for weatherproofing the bundle. It is to be used to insulate an area where two bundles have been spliced together and the tubes connected with a tube fitting.

### To install the jacket patch kit at a splice.

- Cut the ends of both bundles off square, exposing only the needed length of tubing.
- Splice the tubes together using a standard compression type fitting. Wrap the area with high temperature woven fiberglass insulation. Wrapped layers of high temperature insulation should equal that of the manufactured bundle. Wrap fiberglass strip insulation to finished diameter. Secure insulation with fiberglass adhesive tape.
- Cut the black rubber patch so that it extends over the existing jackets 1" (25mm). Remove the protective wax paper backing and wrap it around the patch area. Leave the clear protective layer in place and facing out. Overlap the ends by at least 1/2" (12mm) and press it into place. Use the fiberglass tape to hold it in place and prevent separation of the seams until it cures.

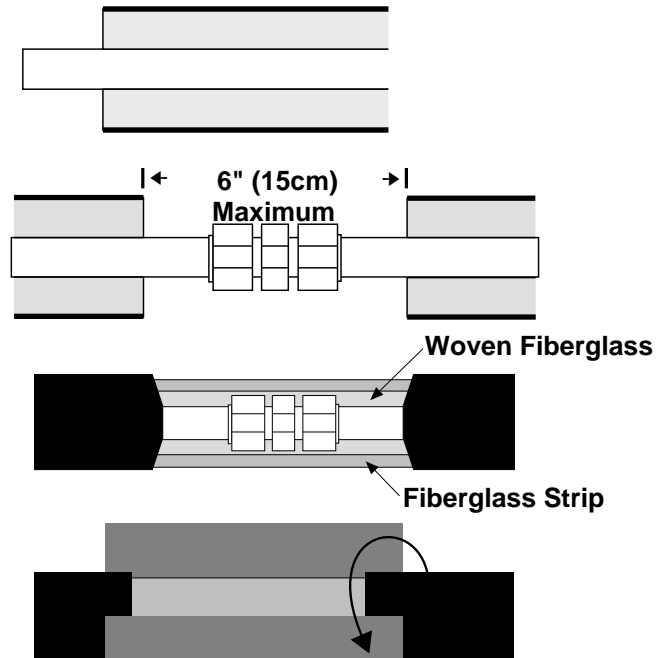

# LINE SENSING THERMOSTAT

The temperature sensing bulb, RTD or thermocouple of the thermostat should be placed in direct contact with the process tube or tubes and not in contact with the electric tracer. Each thermostat is different and specific installation procedures may vary.

## **To install the line sensing thermostat:**

- Locate a suitable mounting location for the thermostat housing. Route the capillary along the bundle away from heat sources other than the tracer in the bundle. (Do not place near process connection or the heater in an enclosure.)
- Locate the tracer in the bundle. The tracer can usually be felt through the bundle and insulation. Make a slit lengthwise along the bundle, opposite the tracer, where the capillary bulb will be placed. The slit should be about 2" (50mm) longer than the length of the bulb and it must go through the insulation and mylar.
- Insert the bulb in the bundle in direct contact with the process tube or tubes. Cut three pieces of the 2" (50mm) wide fiberglass insulating tape about 1" (25mm) less than the length of the slit. For each piece, fold the tape along the cut length making a double layer tape of 1" (25mm) wide. Work each of the three tapes into the slit covering the capillary bulb and under the jacket material.
- Use the fiberglass tape supplied with the jacket patch kit to wrap the bundle over the slit every 1½" (40mm). Secure the capillary to the bundle with the tape for a distance of at least 2" (50mm) from the end of the slit. Apply a liberal bead of sealant, similar to TPKSK, along each side of the capillary.
- Use the black rubber patch supplied with the jacket patch kit and wrap the bundle to seal the slit. Cut the black rubber patch so that it extends 2" (50mm) past the slit in both directions. Remove the protective backing and wrap it around the patch area, overlapping it, and press into place. Wire the switch to the power supply and the tracer per local and applicable codes.



# HC5 CONTROLLER

The MODEL HC5 is economical on/off controller. The HC5 controller is well suited for Heated Hose or TRACEPAK non hazardous installations. Desired control temperature is set with a knob and scale marked in both °F and °C. The controller is equipped with power, heater on, and open heater indication. A local master power switch is located on the outside of the enclosure and a replaceable fuse is located on the front panel.

## ■ Specifications:

- Input: Type J or K thermocouple
- Control Power: 120/240V  $\pm$ 10%
- Output: SPDT relay 20A
- Dead Band:  $\pm$ 5-10°F depending upon set point
- Housing: NEMA 4X
- Ambient Temp: -40°F/C to 150°F (90°C)
- Humidity: 5-95% non-condensing
- Control Scale: 0-800°F(-18-425°C) for Type J Input  
0-2000°F(-18-1090°C) for Type K Input
- Connections: Standard unit accepts customer supplied and located power and sensor connections.  
EP Option includes 6' (1.8M) power cord with integral GFI and factory wired female 5 pin Amphenol connector (120V only).
- Mounting: Surface mounting feet provided.

## ■ Model Number:

- HC5- 20A On/Off Controller
- J- Type J Thermocouple Input
- K- Type K Thermocouple Input
- 120- 120VAC Power
- 240- 240VAC Power
- EP Integral GFI and factory installed power cord and connector (120V only).

- **Example:** On/Off 20A controller for 120V service with type J thermocouple input: Model HC5-J-120





**O'Brien Corporation • 1900 Crystal Industrial Ct. • St. Louis, MO 63114 USA**  
**Phone (1) 314/423-4444 • Fax (1) 314/423-1144 • [obcorp@obcorp.com](mailto:obcorp@obcorp.com) • [www.tubingbundle.com](http://www.tubingbundle.com)**  
Specifications subject to change without notice © 2000 O'Brien Corporation • Bulletin QLT-TPINST-INT • 30 MAR 00