

| CEWKA | AC ~50 /60Hz Volt | | | | DC Volt | | | Wtyczka |
|------------------------|----------------------|-----|-----|------------|------------|-----|-----|---------|
| | 24 | 48 | 110 | 220 230 | 12 | 24 | 48 | |
| Typ A6 Kod ① | A6B | A6C | A6D | A6E | A60 | A61 | A62 | 1/2"NPT |

OPIS
Tolerancja napięcia
AC +15% -10%
DC ± 10%
Stopień ochrony IP65

WYKAZ CZĘŚCI ZAMIENNYCH
1. Membrana

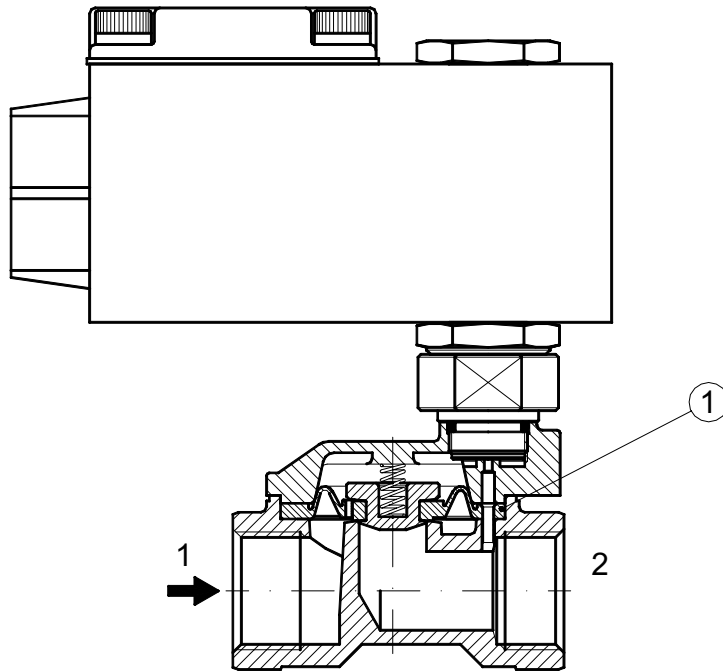

WYMIARY

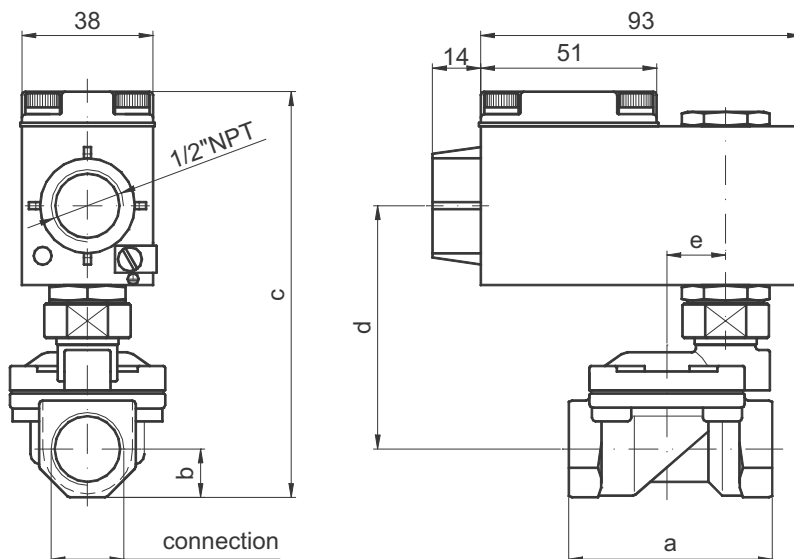

| PRZYŁĄCZE | a | b | c | d | e | Waga kg |
|-----------|----|------|-----|------|------|------------|
| G3/8"Ø12 | 59 | 17 | 118 | 70 | 17 | 1.31 |
| G1/2" | 59 | 17 | 118 | 70 | 17 | 1.31 |
| G3/4" | 79 | 21,5 | 127 | 75,5 | 22,2 | 1.55 |
| G1" | 96 | 27 | 141 | 88 | 30,2 | 2.15 |